

## PLASTX temperature controller and indicator for extruder applications



- Simple to operate
- Universal input
- Selectable controller or indicator modes
- Heat only or heat cool control type
- Process & loop alarms
- Available in 1/16 & 1/8 DIN formats
- Modbus RS485 communications
- Ramping setpoint



**Reduce inventory – single device for heat only, heat/cool control and indicator**

**Fast configuration – plastic extruder specific settings and default parameters to fit the selected mode**

The Plastx extruder temperature controller from West Control Solutions is an economic solution to precision temperature control of extruders. With two package sizes and multiple output configurations, the controller is suitable for twin and single screw extruders, both heat only die and adapter zones, in addition to heat cool for barrel zones. The instrument can also be used in an indicator only mode, allowing one instrument to be used for all applications. With three default parameter sets for Indicator, Heat and Heat/Cool modes, the Plastx controller offers the ultimate in flexibility for the control of industrial plastic extruders.

### Specification

#### Features

Device Modes	PID Controller or Indicator
Control Types	Full PID with Pre-tune, Self-tune, manual tuning, or On-Off control. Heat only or heat & cool
Sensor Input	Universal input for use with thermocouples, PT100 RTDs and sensors with linear DC
Auto/Manual	Selectable from front panel with bumpless transfer
Control Enable	Control ON/OFF selectable from front Keypad
Output Configuration	Up to 3 possible, for control and alarm
Alarm 1 & 2 Types	Process high, process low, SP deviation, band, logical OR / AND. Also 1 loop alarm for process control security. Process alarms have adjustable hysteresis.
Human Interface	4 button operation, 4 digit 10mm red upper & 8mm green lower LED display plus 5 LED indicators

#### Input

Thermocouple	J, K, C, R, S, T, B, L, N & PtRh20%vsPtRh40%.
RTD	3 Wire PT100, 50Ω per lead maximum (balanced)
DC Linear	0 to 20mA, 4 to 20mA, 0 to 50mV, 10 to 50mV, 0 to 5V, 1 to 5V, 0 to 10V, 2 to 10V. Scalable -1999 to 9999, with adjustable decimal point
Impedance	>10MΩ for Thermocouple and mV ranges, 47KΩ for V ranges and 5Ω for mA ranges
Accuracy	±0.1% of input range ±1 LSD (T/C CJC better than 1°C)
Sampling	4 per second, 14 bit resolution approximately
Sensor Break Detection	<2 seconds (except zero based DC ranges), control O/P's turn off, high alarms activate for T/C and mV ranges, low alarms activate for RTD, mA or V ranges

## Outputs & Operations

Control & Alarm Relays  
Control SSR Driver Outputs  
Triac Outputs  
Communications

Contacts SPDT 2 Amp resistive at 240V AC, >500,000 operations  
Drive capability >10V DC in 500Ω minimum  
0.01 to 1 Amp AC, 20 to 280Vrms, 47 to 63Hz  
2 Wire RS485, 1200 to 19200 Baud, Modbus

## Operating & Environmental

Temperature & RH  
Power Supply  
Front Panel Protection  
Standards

0 to 55°C (-20 to 80°C storage), 20% to 95% RH non-condensing  
100 to 240V 50/60Hz 7.5VA, 20 to 48V AC 7.5VA / 22 to 65V DC 5W  
IEC IP66 (Behind panel protection is IP20)  
CE, UL & ULC recognised

## Dimensions

### PLASTX6

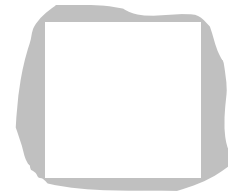
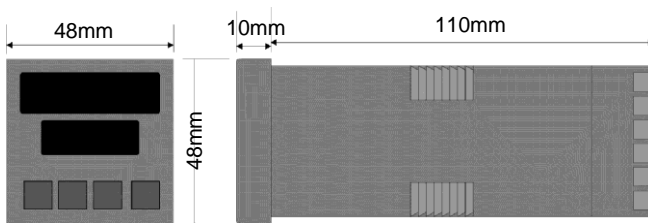

### PLASTX8

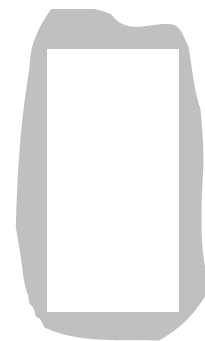
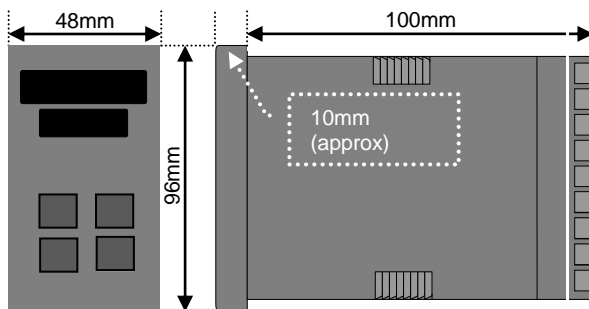

## Wiring Connections

### PLASTX6

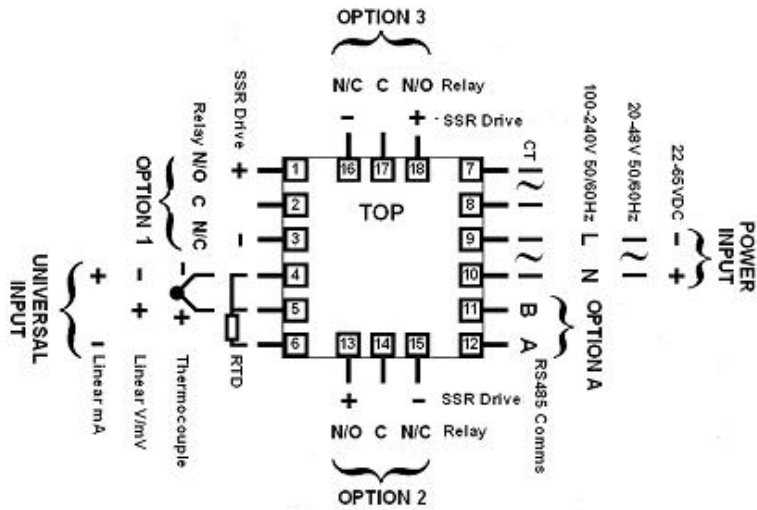

### PLASTX8

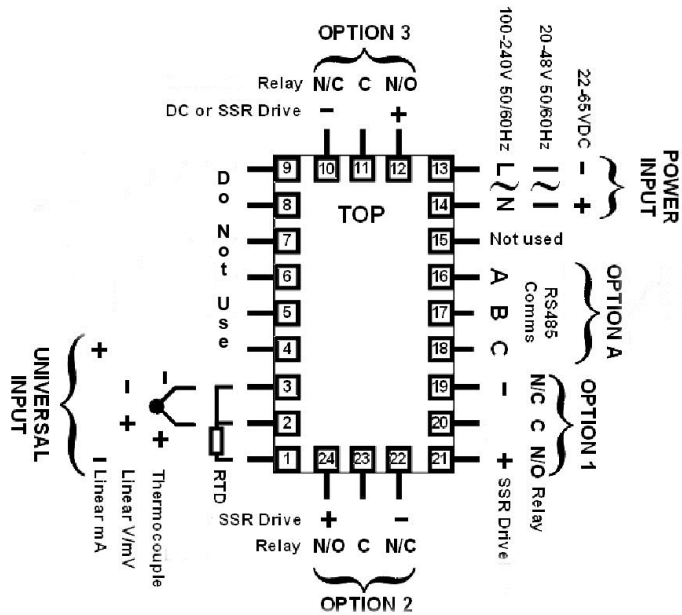

## Ordering Code

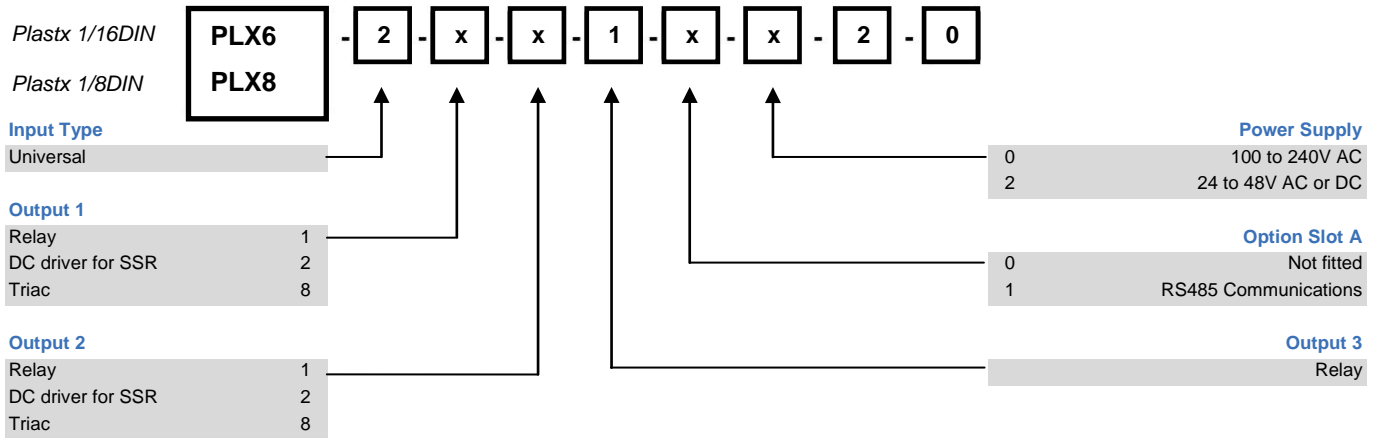

Brochures and datasheets are available for the complete range of WEST Control Solutions products, contact your local sales office for more information or visit our website at [www.west-cs.com](http://www.west-cs.com)

### Austria

T: +43 (0)2236 691-121  
E: AT@West-CS.com

### China

T: +86 400 666 1802  
E: CN@West-CS.com

### France

T: +33 (1) 77 80 90 42  
E: FR@West-CS.com

### Germany

T: +49 (0)561 505-1307  
E: DE@West-CS.com

### UK

T: +44 (0)1273 606271  
E: UK@West-CS.com

### USA

T: +1 800 866 6659  
E: NA@West-CS.com

Specifications are subject to change without notice, as a result of continual development and improvement, E&OE